

GODIAG Full Protocol OBD2 Jumper BENZ EIS Wiring Diagram

W169 W211 W209

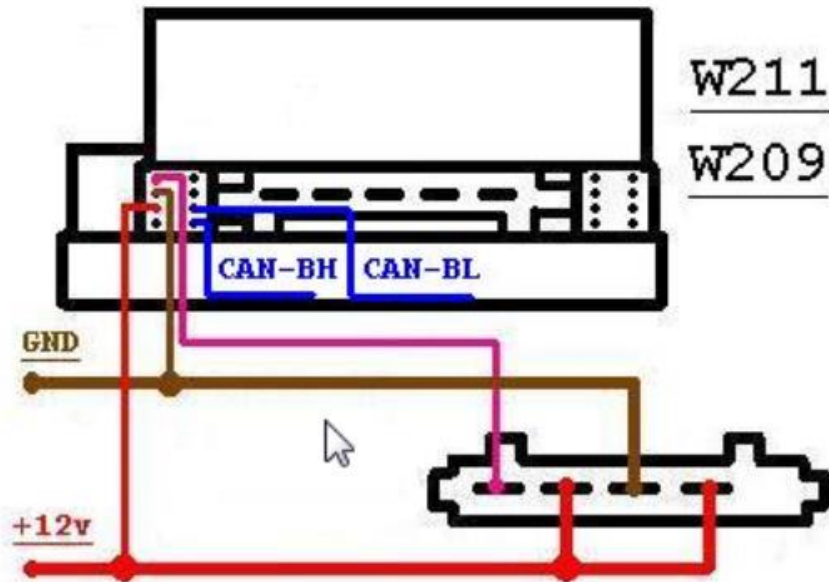

W202 W208 W210

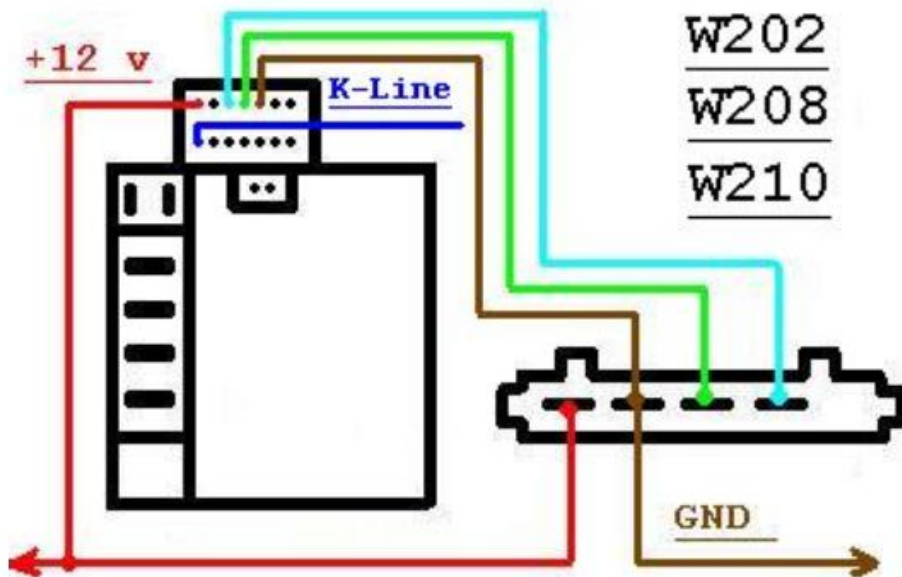

W203 W463 W639

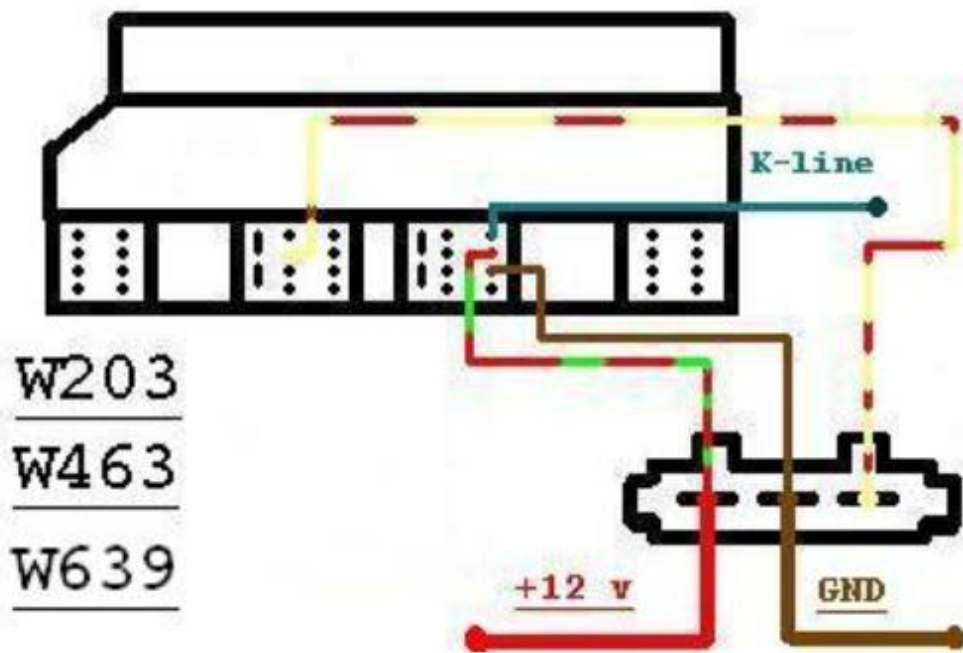

W204 W207 W212

W204, W207, W212

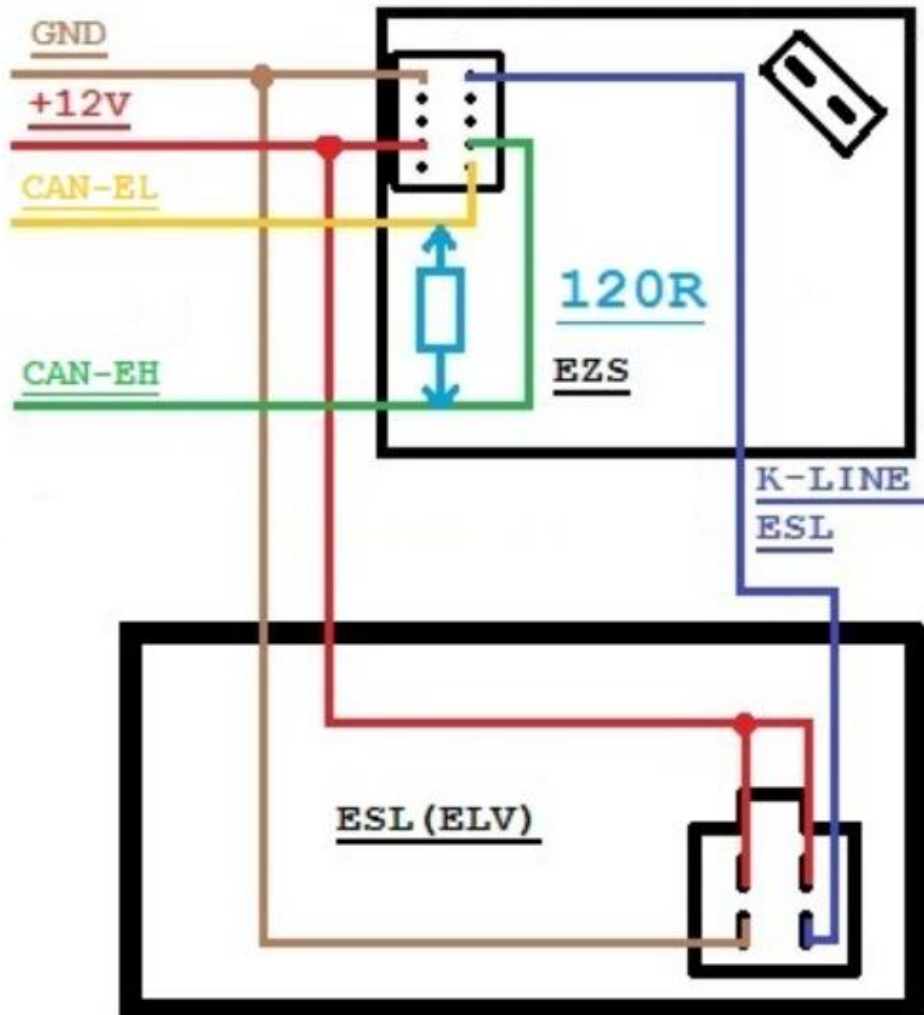

W212 new, W246 W166 EZS

W212, W246, W166

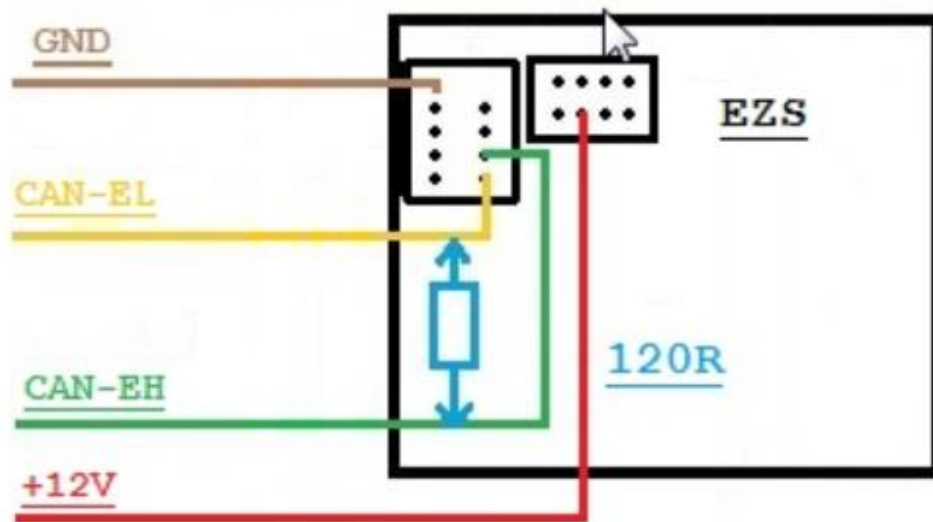

W215 W220 W230

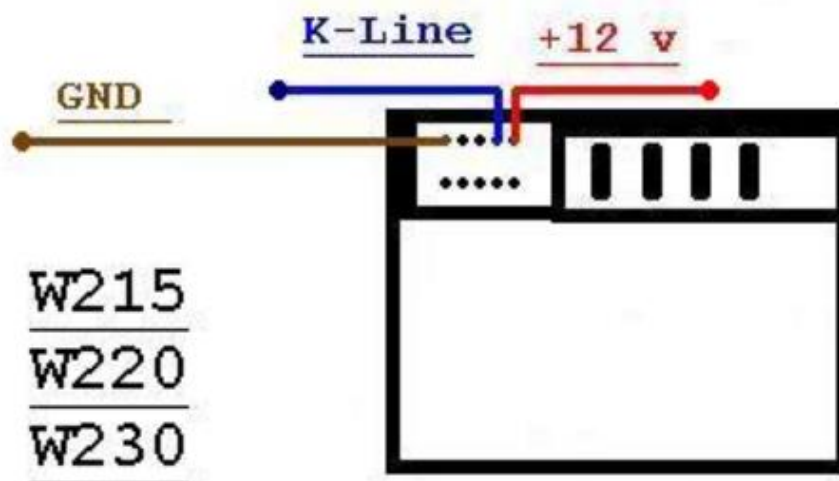

W221 new type

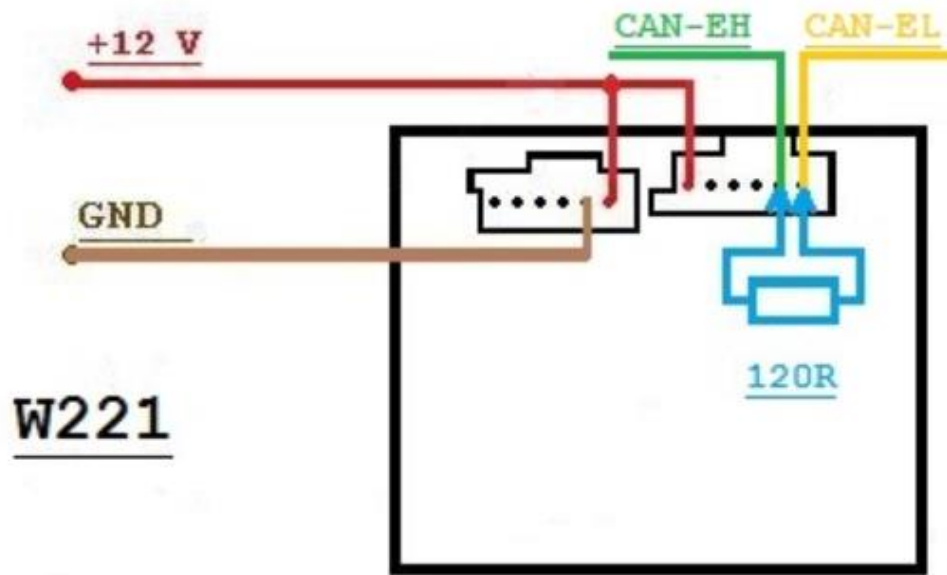

W221 old type

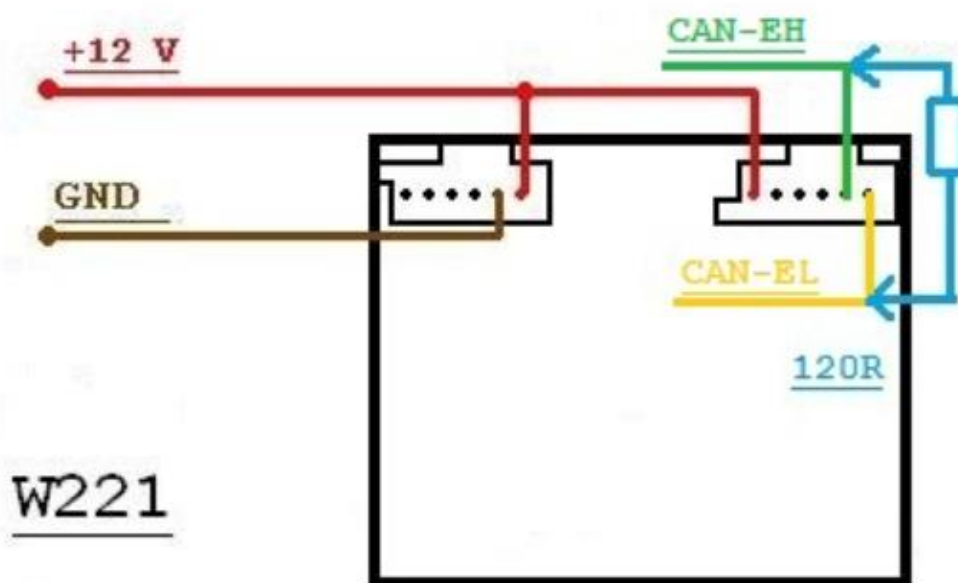

W639 new

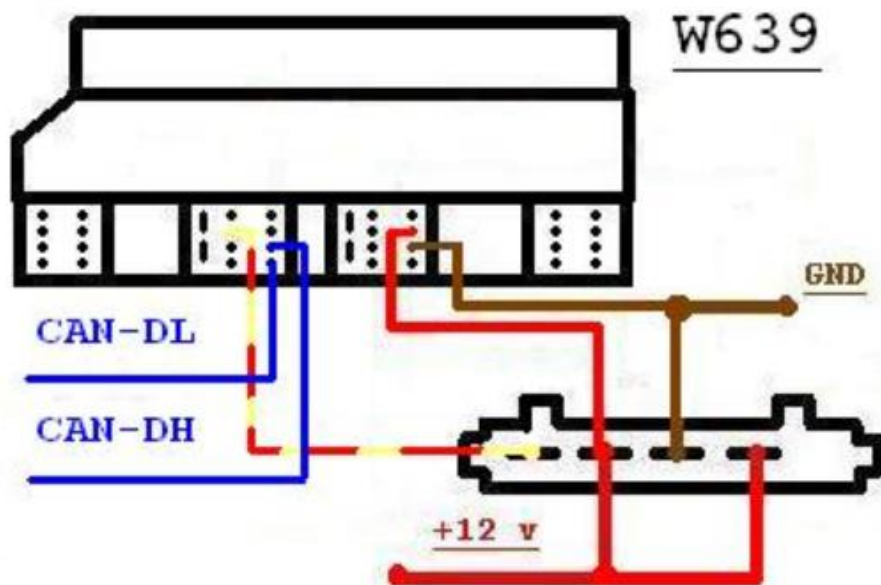

W906

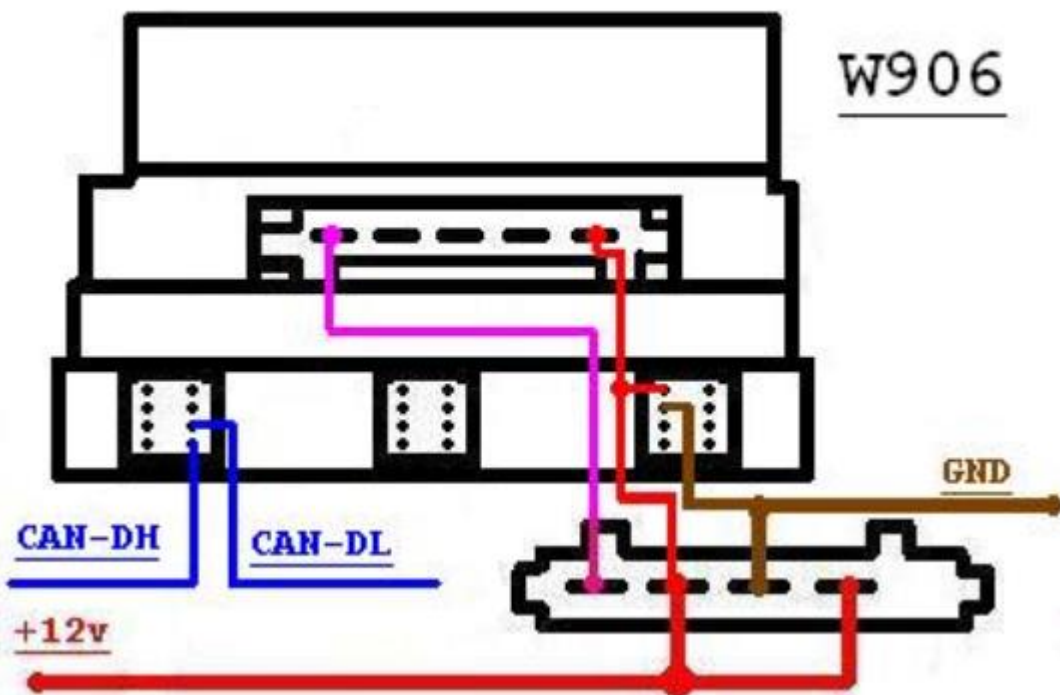

W164 NEC new

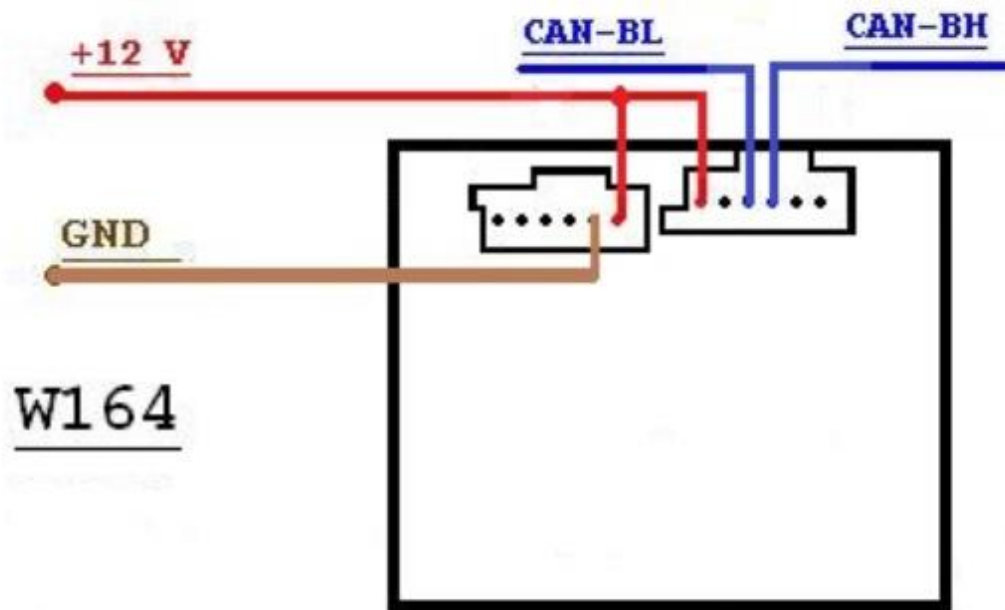

W164 NEC Old

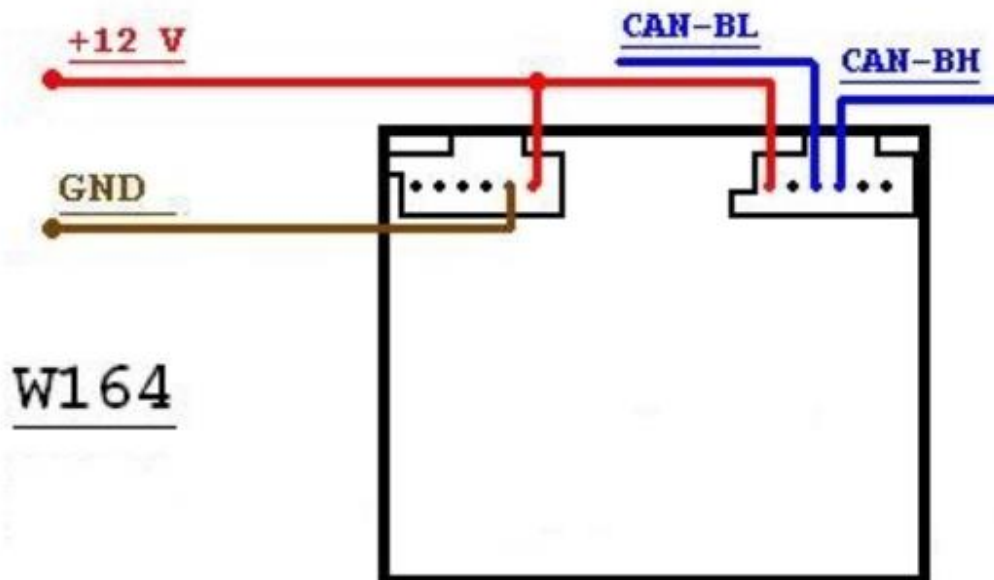

W166 W246

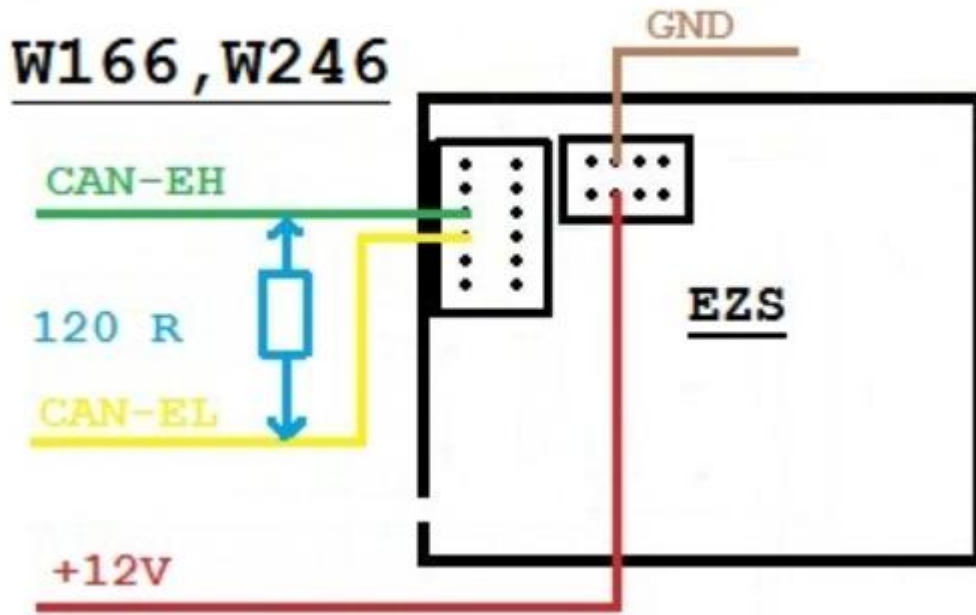

W246 one plug



W246_ one plug pin out

Pin 11---> GND

Pin 10--> Can Hi

Pin 9 --> Can Low

Pin 8 --> Power +12V

MERCEDES EDC16CP31 PIN-OUT

BASIC PINOUT / CONNECTION DIAGRAM OF BOSCH EDC16CP31 ECU FOR MERCEDES VEHICLES.
MB CR SIGN: CR4.11 / CR4.12 / CR4.20 and others CR4.xx.

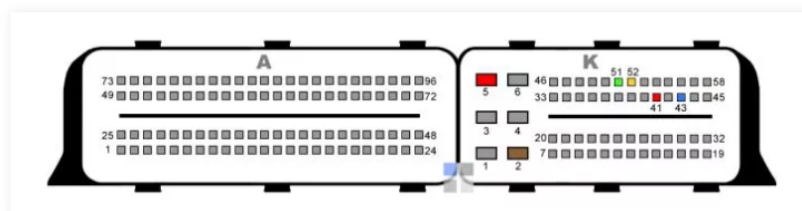

SOCKET "K":

- GND ■ PIN 2
- VCC (15) ■ PIN 5
- VCC (30) ■ PIN 41
- K-LINE ■ PIN 43
- CAN-H ■ PIN 51
- CAN-L ■ PIN 52

MERCEDES BENZ - EDC15 (EDC15C6, EDC15C5) ECU - PINOUT

Basic connection - pinout for Bosch EDC15C6, EDC15C5 Engine Control Units, used in MERCEDES BENZ cars.

- 7 : +12V (term.30)
- 8 : +12V (term.30)
- 5 : GND (term. 31)
- 13 : +12V (term. 15)
- 28 : K Line

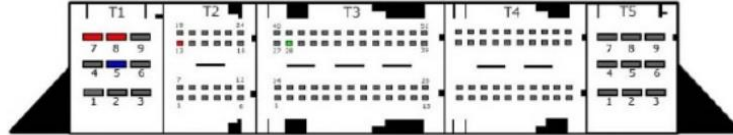

MERCEDES BENZ - EDC16 (EDC16CP31, EDC16CP32) ECU - PINOUT

Basic connection - pinout for Bosch EDC16 CP31, EDC16 CP32 Engine Control Units, used in MERCEDES BENZ cars.

- 5 : +12V (term.30)
- 2 : GND (term. 31)
- 41 : +12V (term. 15)
- 43 : K Line
- 51 : CAN High
- 52 : CAN Low

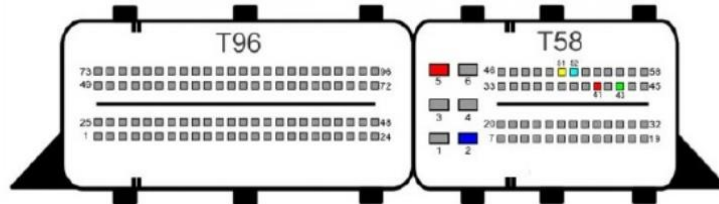

MERCEDES BENZ - EDC16 (EDC16CP36) ECU - PINOUT

Basic connection - pinout for Bosch EDC16 CP36 Engine Control Units, used in MERCEDES BENZ cars.

- 1, 3, 5 : +12V (term.30)
- 2 : GND (term. 31)
- 15, 16 : +12V (term. 15)
- 29 : K Line
- 54 : CAN High
- 41 : CAN Low

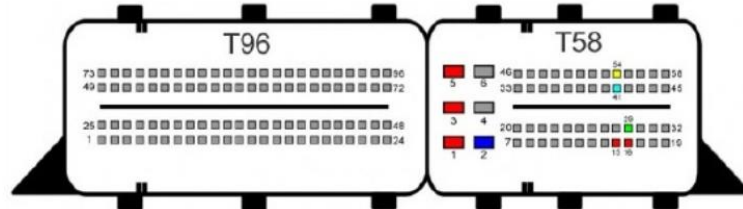

DASHBOARD, IMMOBOX PIN-OUTS DIAGRAMS

- 2 : GND (term. 31)
- 18 : +12V (term. 15)
- 72 : K Line
- 89 : CAN High
- 66 : CAN Low



MCC SMART - MEG 1.X ECU - PINOUT

Basic connection - pinout for Bosch MEG1.x Engine Control Units, used in SMART cars.

- 114 : +12V (term.30)
- 121 : GND (term. 31)
- 103 : +12V (term. 15)
- 108 : +12V (term. 15)
- 110 : K Line

